

TURBOCHARGER SELECTION AND MATCHING CRITERIA IN A HEAVY DUTY DIESEL ENGINE

Kareem Emara, Ahmed Emara, El Sayed Abdel Razek*

Mechanical Power Engineering Department-Faculty of Engineering-Matara – Helwan University, Cairo-Egypt
Mechanical Power Engineering Department-Faculty of Engineering- Misr University for Science & Technology
Cairo-Egypt

Eng_kareem73@yahoo.com , aaarazek@gmail.com and sayedm2000eg@yahoo.com.

Abstract— A turbocharger is certainly one of the fundamental devices being employed to enhance output power of petrol and/or diesel and is of paramount importance for use in heavy duty diesel engines. This work aims to increase the power of a six- cylinder turbocharged, four stroke, direct injection heavy duty diesel engine via replacing its fitted turbocharger with a properly selected and matched one. The matching criteria and the effect of intercooler presence are studied. A performance prediction model for turbocharged engine is created to investigate the engine-turbocharger matching. To address this, a program code has been upgraded and modified to select the suitable engine turbocharger using FORTRAN PowerStation 5.0 language. The study includes also an experimental part; where three types of turbochargers, (namely HX80, HB3 and HX40) are tested. The P- Φ diagram, the engine performance parameters together with the exhaust and soot emissions are measured and compared for the cases of original and best turbocharger (HX80). The developed computer algorithm appears to provide results that are in good agreement, within accuracy of + 5%, with the measured data; a fact that encourages designers to trustfully use it in their selection and matching of a turbocharger to diesel engines.

Index Terms— Heavy duty diesel engine, turbocharger matching, prediction program, engine performance.

1 INTRODUCTION

Power upgrading of internal combustion engine is a qualitative feature. Power upgrade is possible by increasing each fuel and air entering the engine cylinders. By increasing the air inlet to the combustion chamber, the condition for better combustion and engine power enhancement is achieved. Many different methods are used for increasing the amount of air inlet among of them is the turbocharging. But the matching of the compressor and turbine to an internal combustion engine is a complicated balance of many design considerations [1 and 2]. Appropriate turbocharger components must be carefully selected to match a given engine size. A procedure of finding optimal turbocharger for an engine based on the experience with turbo matching is introduced [3]. This deals with one of the possible ways, using a 1-D model of turbine. An application of the procedure is relatively fast and allows for finding suitable turbocharger without a need to calculate all feasible combinations of turbine and compressor maps provided by turbocharger manufacturers, amended by a compressor map extrapolation and combined with a 1-D engine simulation package. The availability analysis, operation as well as examination of the various engine parameters effect on a turbocharged diesel engine performance, under transient load conditions has already been conducted [4 and 5]. A practical application in turbocharger matching is also provided to show how this new map can be directly employed in engine design [6].

Finally the present work aims to:

- 1- Select and match an appropriate turbocharger to the tested engine in order to increase the engine power.
- 2- Compare the engine performance and combustion characteristics when using the original turbocharger and selected one.
- 3- Compare the measured data and simulated one from FOR-

TRAN code to validate this code.

2. PROCEDURE FOR TURBOCHARGER MATCHING

The concept of turbocharger matching in general is to optimize the selection of compressor and turbine combination in order to satisfy the required boosting characteristics for the specified range of engine operating conditions. Ideally, the compressor efficiency should be at its maximum in the main operating range of the engine at full load. Also the distance to the surge line should be sufficiently large as possible as can. To address this target the model of turbocharger and engine is constructed. If an analytical method is available for calculating the engine performance with different turbocharger, hence actual engine testing may begin with different turbocharger close to the optimum matching. Development time and hence cost is reduced. In straightforward, many parameters are assumed in first to determine the operating conditions of engine. Therefore, the most parameters will be calculated from the designed program with FORTRAN language in a large number of iterations. The manifold pressure and instantaneous turbocharger speed will be predicted at each integration step, and the compressor (or turbine) mass flow rates and efficiencies will be determined from the turbomachinery performance maps. The calculations will be iterative since several estimates of certain parameters are required. A typical procedure for a heavy duty diesel engine turbocharger matching might be as follows:

- 1- Estimate the pressure ratio of the compressor (P_2/P_1).
- 2- The perfect gas law is used to calculate the inlet manifold temperature T_2 and the air density after assuming a representative value of compressor efficiency.
- 3- Assume a realistic value for volumetric efficiency of

the engine (based on inlet manifold and density) and calculate the air flow rate

$$(\dot{m}_a) = (N \cdot V_{sw} \cdot \rho) / 2 \quad (1)$$

- 4- Assume a realistic minimum air/fuel ratio for the type of diesel engine involved and hence estimate the temperature rise ($T_3 - T_2$) across the engine.
- 5- Estimate the turbine efficiency, or the overall efficiency of the turbocharger, from manufacturers' data or previous experience with similar machines.
- 6- Check that the pressure drop between the inlet and exhaust manifold ($P_2 - P_3$) is adequate for good scavenging or minimum pumping work during the gas exchange period
- 7- Calculate the mass flow parameter for the turbine, where $\dot{m}_e = \dot{m}_a + \dot{m}_f$ (2)
 And draw the mass flow parameter of turbine $\dot{m}_e \sqrt{T_3 / P_3}$
- 8- Calculate the mass flow parameter of the compressor ($\dot{m}_a \sqrt{T_1 / P_1}$) and draw this point in the compressor map.
- 9- Check that if the product of compressor and turbine efficiencies at the operating point is compatible with that assumed. Adjust and recalculate if necessary.

Now it's clear that many assumptions have been made in the above procedure, it follows that the answer will be an approximation.

3. EXPERIMENTAL SETUP

A real heavy duty diesel engine, type- OT-62 serial no. MHYT02ZKC with nominal power 300 HP, is used in the experimental study. The experimental setup includes measuring instrumentation used to obtain the engine performance as well as its emission behavior is shown in Fig. 2. The specification of this engine is a six-cylinder, in line, water cooled, of 150 & 180 mm bore and stroke, respectively, with compression ratio 15: 1 and the rated output is 300 HP at 1800 rpm. It is tested at the research laboratory in the Faculty of Engineering, Helwan University- Egypt. The engine was attached in correct alignment with the dynamometer; this assists steady running and eliminates the vibration. External loading is carried out by a Froude hydraulic dynamometer (type D. P. Y). A cardan shaft with two universal joints and of a design which prevents whirling was provided to connect the dynamometer to the engine. The maximum break power of the water brake could reach to 500 BHP at 3500 rpm. The dynamometer is used to measure the engine torque with a mechanical scale. This dynamometer is claimed to be accurate to within $\pm 0.025\%$ of nominal rating. All engine fluid temperatures are monitored using K-type thermocouples. The engine has provisions for varying the fuel injection timing. High accuracy, high resolution, high pressure range up to 6000 psig and Low-range flowmeter (FTB500 Series) was used for determining the fuel consumption of the engine during tests. The fuel consumption per hour was calculated. Pressure drop according to orifice flow meter is used to measure the air delivered to the engine. This orifice plate is fixed before inlet of the compressor with long distance to ensure steady flow of air. Engine speed (rpm) was measured by toothed gear and magnetic pick up combi-

nation installed on the engine output shaft. But the turbocharger speed needs to construct special circuit consist of sender and receiver to account the shaft rotation. Engine coolant temperature was controlled by heat exchanger tower system which was designed to thermostatically set and hold a specified coolant outlet temperature. A test consoles contain the dynamometer controls along with conventional gages for indicating engine oil pressure, engine speed, water pressure to and out the dynamometer, besides, the temperatures of inlet and outlet water of the engine & the dynamometer, and exhaust gases temperatures. In addition, the pressure and temperature values in the most relevant locations along the intake and exhaust system, as well as of high frequency pressure data at the same locations are detected. Also the in cylinder high pressure sensor (ICP- Model 113B22-up to 350 Pa) is fitted into the engine cylinder to measure the pressure in cylinder.

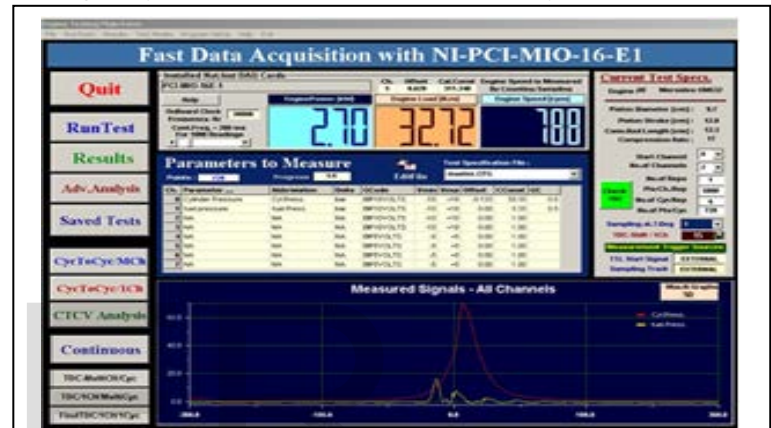

Fig. 1. Data acquisition software main program window

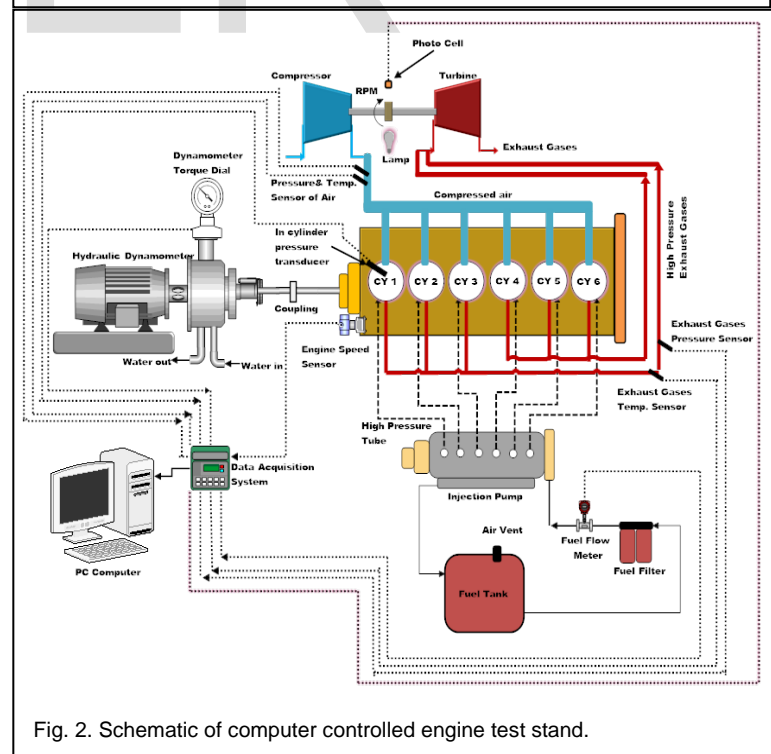

Fig. 2. Schematic of computer controlled engine test stand.

The signals from the pressure transducers, optical sensors and thermocouples, engine speed and crank angle of rotation sen-

sors were digitized and recorded in PC with the help of Lab-View software for later analysis using a data acquisition card- NI model M series multifunction DAQ for USB -16 Bit, 250 KS/s, up to 80 analog input. This software is designed, specially, to integrate the data from all measuring devices and sensors and present it in PC window.

The used software package has been developed in visual basic in order to automate the measuring and reporting procedures. Measuring the crank angle trace of the pressure inside the engine cylinder, is mainly an important objective. The program may be used for the simultaneous measurements up to 8 differential signals. Also the software is designed to calculate another parameter such as in-cylinder temperature, fuel burning rate and heat release rate with the assistance of the measuring data (Fig.1). A sketch of the engine layout with the location of transducers and sensors used during the measurements is shown in Fig. 2.

4. RESULTS AND DISCUSSION

It is clear that a turbomachine is not ideally suited to operate in conjunction with a reciprocating machine, hence the combination of diesel engine and turbocharger must be planned with care. Matching of the correct turbocharger to a diesel engine is of great importance and is vital for successful operation of a turbocharged diesel engine. In this section, all the results are presented and discussed. First, deal with choosing the suitable turbocharger according to good matching. Second, the results of engine performance with chosen turbocharger at different loads and engine speeds are discussed.

4.1. TURBOCHARGER MATCHING

A comparison is done between three different turbochargers named, HX80, HB3 and HX40. Since the heavy duty diesel engines operates over a wide speed and load range, the air flow requirements cover larger areas of the compressor map. A typical superimposition of engine air flow on a compressor map is given in figure 3, showing lines of constant engine speed (1000, 1200, 1400, 1600, 1800, 2000 and 2200 rpm) for all types. It is clear from the three maps that HX80 type is an acceptable choice, since the operational area is far from the surge line and lies in an area of high efficiency.

On the other hand, when the load is changed at constant speed similar behavior is observed with lower pressure ratio up to 2.7 and lower turbocharger efficiency; with operating conditions having safe margin from the surge line and close to chock line especially at low part load up to 25% as shown in figure 4. The figures 3 and 4 revealed that HX80 type is preferred, since the operational area is clear in margins from the surge and chock lines and most of engine speed lines lie in the area of high efficiency with range operating pressure ratio of 2:4.5 with average value of 3.

The presence of the compressor is to raise the pressure before inlet manifold of the engine and not to increase the temperature of air. Therefore the effect of intercooler existence will be studied to ensure if it can be neglected to reduce the engine size. Due to intercooler presence the air mass flow rate increased by 1.7 % which is not sensible and can be neglected

which allowing the reducing of the engine size and components. This also will reduce the maintenance of turbocharger and more suitable for engine size constraints.

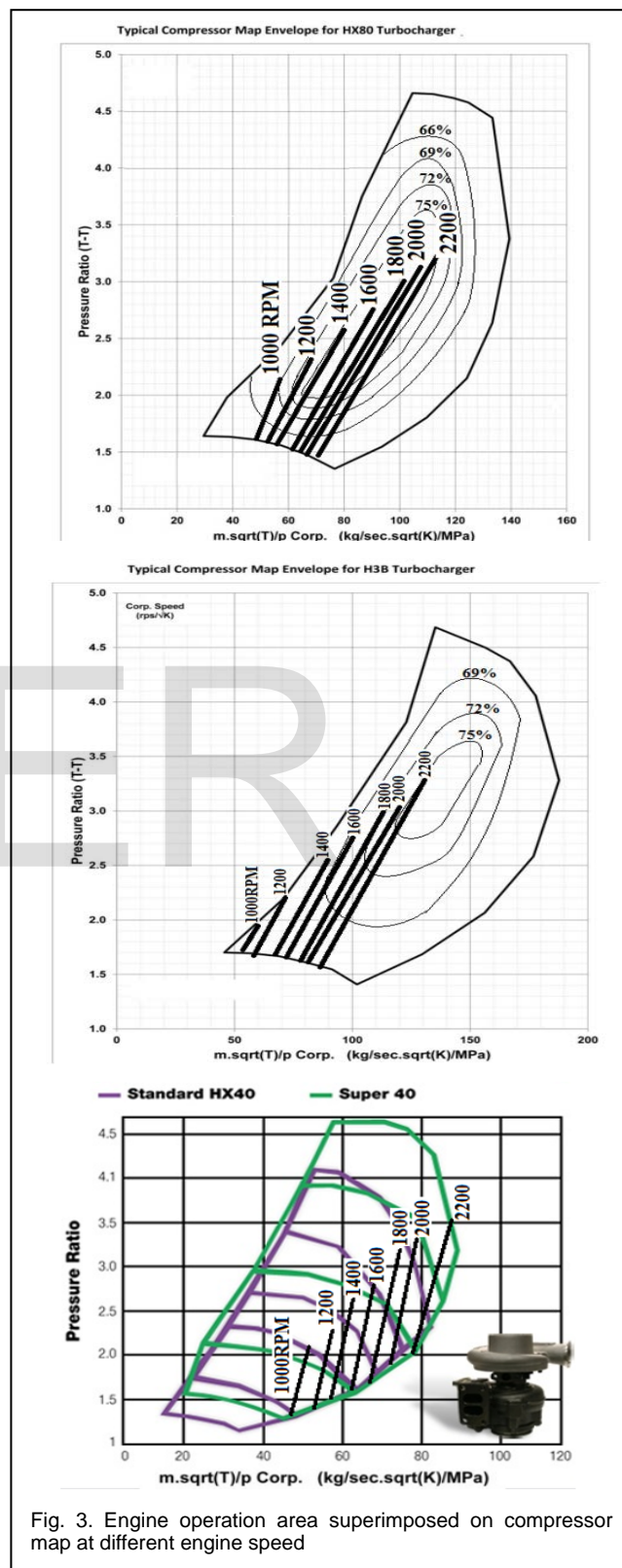

Fig. 3. Engine operation area superimposed on compressor map at different engine speed

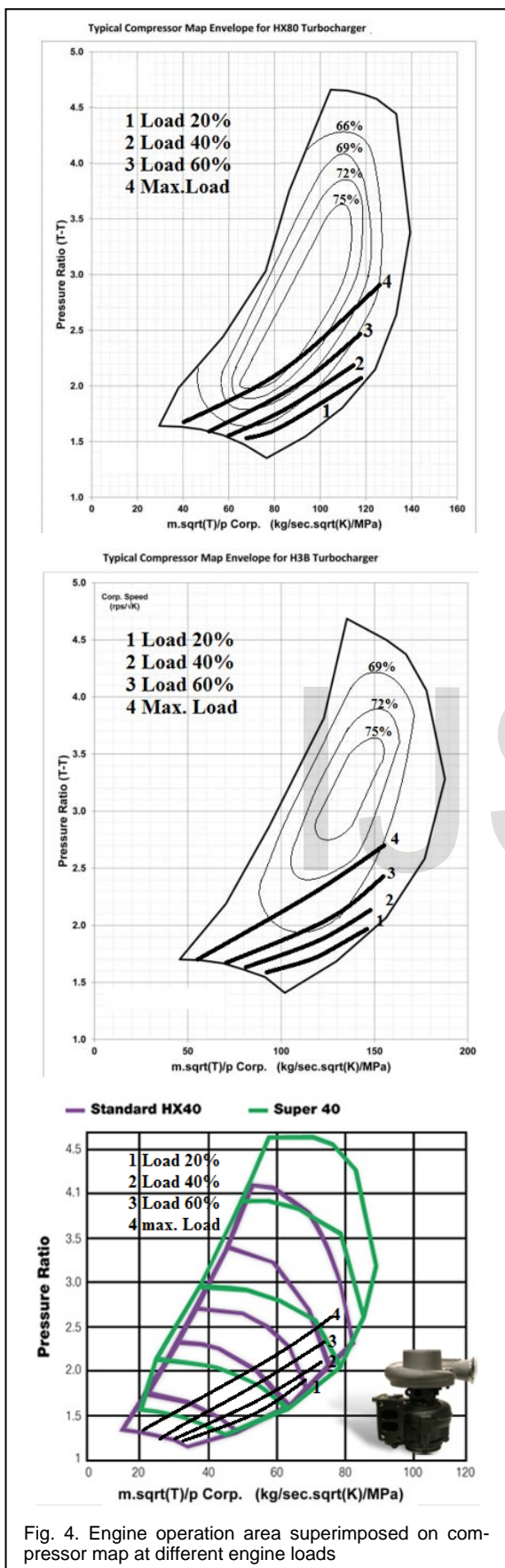

Fig. 4. Engine operation area superimposed on compressor map at different engine loads

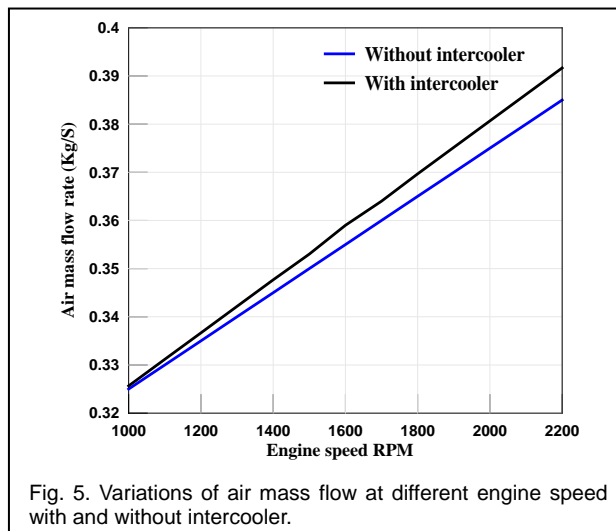

Fig. 5. Variations of air mass flow at different engine speed with and without intercooler.

4.2. COMBUSTION CHARACTERISTICS AND ENGINE PERFORMANCE

A comparison using the new turbocharger (HX80) and the original one is generated to see the variations in engine combustion characteristics and performance. Combustion parameters like cylinder pressure, peak cylinder pressure, and combustion zone temperature and heat release are discussed. Performance parameters like brake power and brake specific fuel consumption are discussed with variable engine loads and speeds.

4.2.1. CYLINDER PRESSURE AND TEMPERATURE

The cylinder pressure in internal combustion engines depends on the fuel-burning rate during the premixed burning phase. An increasing of cylinder pressure leads to good combustion and increasing of heat release rate. Figure 6 shows the typical measured of in-cylinder pressure variation with respect to crank angle for original turbocharger and new HX80 respectively at rated engine speed. It can be noted that the cylinder pressure for engine equipped with the original turbocharger is lower than that when HX80 is used due to the characteristics of HX80 turbocharger over the original.

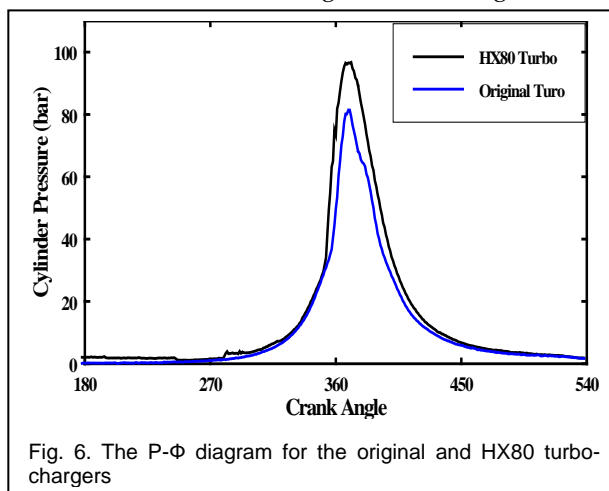

Fig. 6. The P-φ diagram for the original and HX80 turbochargers

The maximum pressure obtained from engine at HX80 is

greater than that one of the original turbocharger by 20% while the maximum pressure in two cases is closer to TDC.

The combustion characteristics is modified due to increasing the amount of air which producing more CO₂ and hence more heat is released from the exhaust gases. Thus, the peak temperature when using HX80 with the engine is higher than when original turbocharger is used by 20%. Figure 7 shows the variations of In-cylinder temperature with crank angle for original and HX80 turbochargers at rated engine speed. The maximum temperature of HX80 is not closer to TDC than original. This because perfectly combustion of fuel which needs more amount of air and longer time.

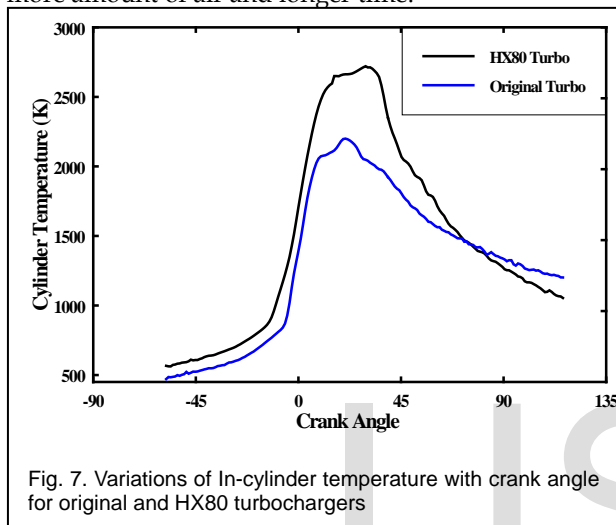

Fig. 7. Variations of In-cylinder temperature with crank angle for original and HX80 turbochargers

4.2.2. HEAT RELEASE RATE

The fuel is often injected into the engine cylinder near the end of the compression stroke in diesel engines, just a few crank angle degrees before top dead center [1]. The liquid fuel is usually injected at high velocity as one or more jets through small orifices or nozzles in the injector tip. It atomizes the liquid fuel into small droplets and penetrates into the combustion chamber. The atomized fuel absorbs heat from the surrounding heated compressed air, vaporizes, and mixes with the surrounding high-temperature high-pressure air. As the piston continues to move closer to top dead center (TDC), the mixture (mostly air) temperature reaches the fuel's ignition temperature. Instantaneous ignition of some premixed fuel and air occurs after certain ignition delay period. This instantaneous ignition is considered the start of combustion (also the end of the ignition delay period) and is marked by a sharp cylinder pressure increase as combustion of the fuel-air mixture takes place. Increased pressure resulting from the premixed combustion compresses and heats the unburned portion of the charge and shortens the delay before its ignition. It also increases the evaporation rate of the remaining fuel. Atomization, vaporization, fuel vapor-air mixing, and combustion continue until all the whole injected fuel vanishing.

As equivalence ratio increases, the sharp increases in rapid combustion stage because the increased equivalence ratio improves the mixture heat capacity, reducing the in-cylinder temperature and weakening the low-temperature heat release process of the fuel.

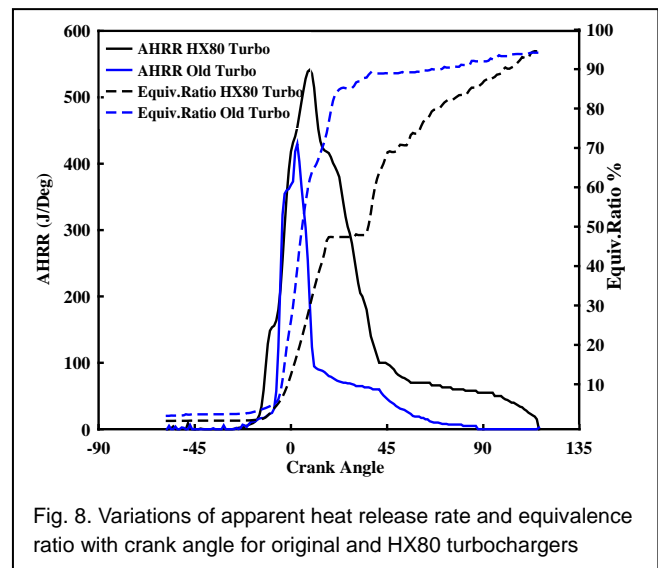

Fig. 8. Variations of apparent heat release rate and equivalence ratio with crank angle for original and HX80 turbochargers

The second stage of mixing controlled combustion is shortened with the increased equivalence ratio because increased fuel concentration facilitates mixture reactivity. It's clear from figure 8 that the heat release rate and heat transfer rate increased using HX80 which increases also the engine pressure and power at rated engine speed.

4.2.3. MAXIMUM IN-CYLINDER PRESSURE

Maximum in-cylinder pressure is an indication to the increase of power produced from the engine. This is what was observed when measuring the maximum pressure with different loads for both turbochargers. The maximum cylinder pressure in all loads when using HX80 is higher than the original turbocharger with value nearly 10bar at different engine speed (Fig.9).

4.2.4. BRAKE POWER (BP) AND BRAKE SPECIFIC FUEL CONSUMPTION (BSFC)

The brake power and torque variation with HX80 and original turbocharger are presented in figures 10 and 11 respectively. As the amount of air is increased, the engine power is improved due to combustion enhancement which causes a reduction in the BSFC. Also, the power to weight ratio will be increased according to power upgrading. The rated maximum engine speed location is changed from 1800 to 2000 RPM where the maximum power is achieved (figure 10). But this change has no noticeable effect on the engine performance.

Diesel engines produce more torque due to their higher compression ratio. Higher pressure in the cylinder and higher forces on the connecting rods and crankshaft require stronger, heavier components. Heavier rotating components prevent diesel engines from acceleration for a given displacement. Comparing engines based on (maximum) torque is just as useful as comparing them based on (maximum) RPM. From figure 12, the engine torque is increased by 17.2% which is good achieving in diesel engine when using the HX80 turbocharger.

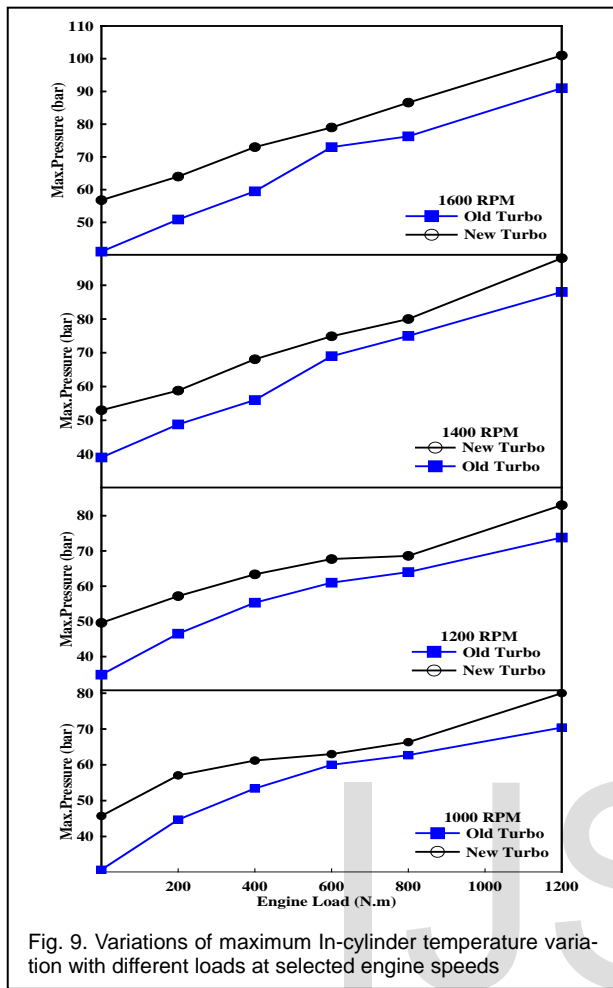

Fig. 9. Variations of maximum In-cylinder temperature variation with different loads at selected engine speeds

The variation of the brake specific fuel consumption as a function of engine speed is illustrated in fig.12 in a comparison of the performance curve. Generally BSFC gradually decreases as engine speed increases, reaches a minimum value (best economic) due to good combustion of fuel, and then increases again at high engine speed. Finally, the engine BSFC using HX80 at all engine speeds is lower than that of the original one by 5.8 %.

Emissions control is of the legal requirements governing air pollutants released into the atmosphere. Diesel exhaust is the gaseous exhaust produced by the diesel engine plus any contained particulates. Its composition may vary with the fuel type or rate of consumption or the air amount.

The carbon monoxide amount is decreased due to complete combustion of fuel while HX80 turbocharger is tested. The cylinder temperature increase leads to increase the chances of NO formation in case of using HX80. But this increasing has no significant or noticeable effect (see figure 13).

The soot number is an indication to the unburned fuel which comes from insufficient air. Also, there are particles of unburned carbon are existing in the exhaust gases of engine when using the old turbocharger which increase the BSFC. Figure 14 proves that the modified engine has lower values of

soot number according to the improvement in combustion process which inhibits soot formation.

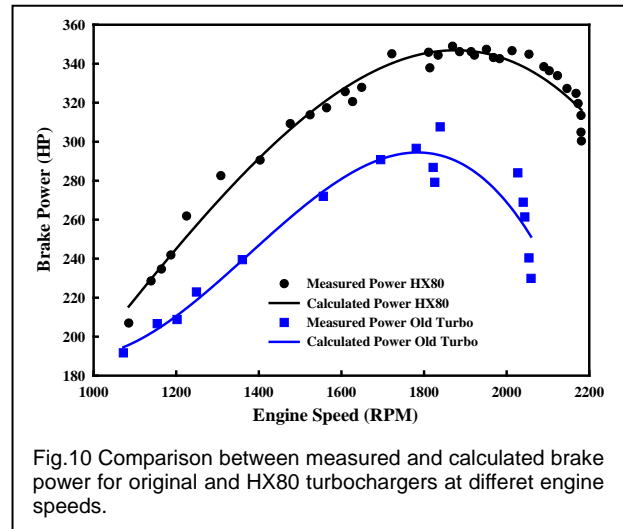

Fig.10 Comparison between measured and calculated brake power for original and HX80 turbochargers at different engine speeds.

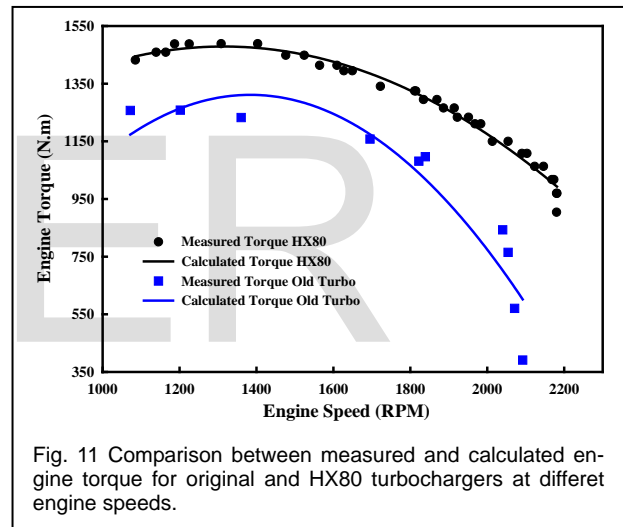

Fig. 11 Comparison between measured and calculated engine torque for original and HX80 turbochargers at different engine speeds.

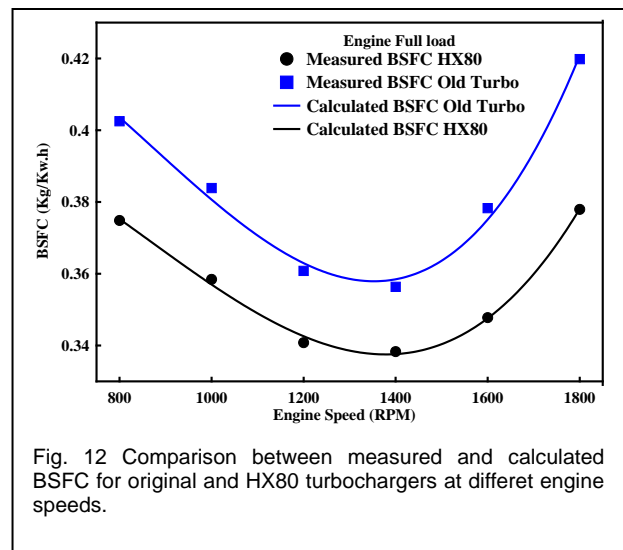

Fig. 12 Comparison between measured and calculated BSFC for original and HX80 turbochargers at different engine speeds.

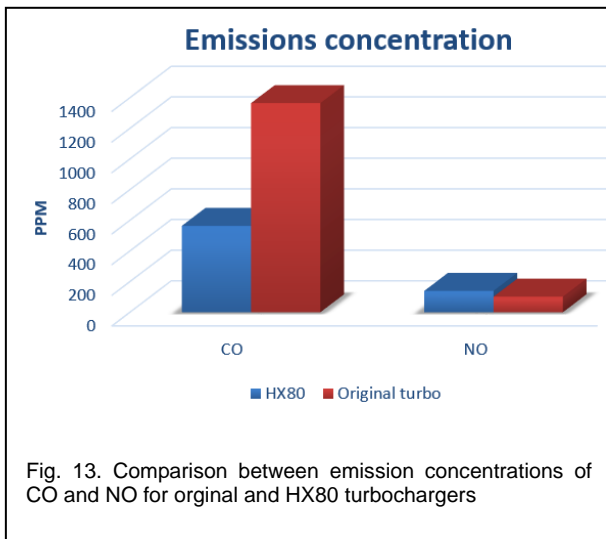

Fig. 13. Comparison between emission concentrations of CO and NO for original and HX80 turbochargers

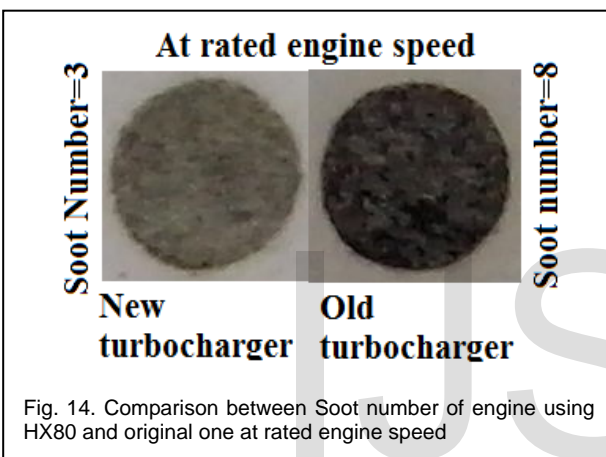

Fig. 14. Comparison between Soot number of engine using HX80 and original one at rated engine speed

5. CONCLUSION

Turbocharger has always been an effective way to increase engine's specific power. The turbocharger selection and/or matching are very important to increase the power to weight ratio also to reduce the cost and evaluation time. The major technical achievements of this study may be summarized as follows:

- 1- The selected and properly matched HX80 turbocharger that replaces the originally fitted turbochargers appears to provide not only better engine performance parameters but also comparatively lower emissions as being reflected by:
 - (a) The increase of maximum in-cylinder pressure by as much as 20% over all loads.
 - (b) Enhancement of heat release rate; indicating improved fuel/air mixing and reaction rates.
 - (c) Increase of maximum engine power from 300 HP (with original turbocharger to 350 HP; a marginal increase of about 17%.
 - (d) Increase of maximum engine torque from 1200 Nm (with original turbocharger) to 1450 Nm ; a marginal increase of about 17.2% leading to better traction.
 - (e) Lowering engine BSFC by 5.8% when using HX80.
 - (f) The soot amount has a smaller value when using HX80.

- 2- The developed computer algorithm appears to provide results that are in good agreement with measured data; a fact that encourages designers to trustfully use it in their selection and matching of a turbocharger to a diesel engine.

REFERENCES

- [1] M. Muqem and M. Ahmad, "Turbocharging of diesel engine for improving performance and exhaust emissions: a review", *IOSR Journal of Mechanical and Civil Engineering (IOSR-JMCE)*, 278-1684, p-ISSN: 2320-334X, Volume 12, Issue 4 Ver. III, PP 22-29, Jul. - Aug. 2015.
- [2] B. Dev, R. Saravanan, R. Pugazhenthii and M. Chandrasekaran", Experimental investigation of turbocharger mapped by datalogger in i.c. engine", *ARP Journal of Engineering and Applied Sciences*, vol. 11, no. 7, april 2016
- [3] K. Emara, A. Emara and E. A. Razeq," Turbocharging of a heavy duty diesel engine for a specific power and performance enhancement", *Proceedings of the ASME, International Mechanical Engineering Congress and Exposition*, November 13-19, 2015, Houston, Texas, USA.
- [4] M. Yuan, B. Chen and J. Zhang," Analysis of the combustion efficiencies and heat release rates of pool fires in ceiling vented compartments", *Rocedia Engineering*, 62-275 - 282, 2013.
- [5] M. Tancrez, J. Galindo, C. Guardiola, P. Fajardo and O. Varnier," Turbine adapted maps for turbocharger engine matching", *Experimental Thermal and Fluid Science* 35 -146-153, 2011.
- [6] K. Emara, A. H. El -Askary, S. A. Wilson and A. R. Syam, "Theoretical investigation into a pressure wave supercharger", *Engineering Research Journal*, Vol.35, No.2, and PP: 109-121, 2012.
- [7] A. Alberto and B. Oretti," Numerical evaluation of the performance of a compression ignition cng engine for heavy duty trucks with an optimum speed power turbine", *International Journal of Engineering and Technology Innovation*, vol. 1, no. 1, pp. 12-26, 2011.
- [8] S. S. Sandhu, M. K. G. Babu and L. M. Das, "Performance and combustion characteristics of a typical motor bike engine operated on blends of cng and hydrogen using electronically controlled solenoid actuated injection system," *ARP Journal of Engineering and Applied Sciences*, vol. 6, no. 2, february 2011.
- [9] R.Senthilkumar,M.Prabu and M.Sukumar, " Performance, Emission and Combustion Characteristics of a CI engine Using Karanja oil Methyl Ester as a biodiesel with Tyre Pyrolysis Blends," *International Journal of Engineering Science and Innovative Technology (IJESIT)* Volume 3, Issue 4, July 2014.
- [10] M. Shahabuddin, A.M. Liaquat, H.H. Masjuki, M.A. Kalam, M. Mofijur, "Ignition delay, combustion and emission characteristics of diesel engine fueled with biodiesel," *Renewable and Sustainable Energy Reviews*- 21 (2013) 623-632.
- [11] U. Kesgin," Study on the design of inlet and exhaust system of a stationary internal combustion engine", *Energy Conversion and Management* 46 (2005) 2258-2287.
- [12] Z. Liu, X. Jun and C. Wang," Numerical simulation for exhaust manifold based on the serial coupling of STAR-CCM+ and ABAQUS", *Research Journal of Applied Sciences, Engineering and Technology* 6(20): 3903-3909(2013), ISSN: 2040-7459; e-ISSN: 2040-7467.
- [13] M.Varma and L Suresh," Exhaust manifold design - FEA approach", *International Journal of Engineering Trends and Technology (IJETT)* 2014- Volume17 Number 10-Nov.